



REFRACTORIES — FOR — INTEGRATED STEEL



Global **Refractory** Solutions



ABOUT ALLIED

Allied Mineral Products is a world leader in the design and manufacture of monolithic refractories and precast shapes. With strong sales and service teams in the foundry, aluminum, steel, heat treat/forge and industrial markets, our success is based on our dedication to *Being There Worldwide with Refractory Solutions*.

Producing quality, consistent products is top priority at Allied and we have the products to meet your refractory needs. Our extensive product line includes innovative refractory technology and longstanding refractory alternatives.

Allied's focus on quality at every stage in the production process is unparalleled. A stringent raw material standard and global quality control testing before and after each batch is produced, provides customers with consistent products. We provide quick response times to any urgent request through flexible manufacturing systems at all our manufacturing facilities.

Refractory Solutions and Technical Support for every step of the process

ENGINEERING & RESEARCH

We start by gaining a detailed understanding of your specific needs. Our team then evaluates operating criteria and physical design parameters to create a detailed Engineered Design encompassing:

- Optimized product zoning
- Thermal models to optimize and validate designs
- Proven safety lining system designs

We are focused on developing new products, improving existing ones and perfecting installation techniques. Product testing and development is conducted in our state of the art research and technology centers. Our wide variety of high performance refractories use superior raw materials vigorously tested in our modern labs and tailored to unique installation and application condition requirements.



Contents

- About Allied
- Innovative product technology
- Technical Support from AMTS
- Blast Furnace Solutions
- Casthouse Solutions
- Reheat Furnace Solutions



Learn more at
alliedmineral.com/solutions/steel/



PRODUCT INNOVATIONS

NEW TECHNOLOGY

GRAPHITE & CARBON ANCILLARY PRODUCTS

GC and HC Product Lines | WE CAN FILL THE VOID

Allied offers a comprehensive collection of carbon and graphite based cements, mortars, ramming materials and grouts. These dependable, industry-leading products are designed to fulfill ancillary needs in blast furnaces, cupolas and ferroalloy furnaces.



Original Allied Line	
HC3F	Single-component, clean carbon mortar
HC4F	Single-component, water-based grout for cold grout applications
HC5F	Single-component grout for hot installations
HC6F	Two-component collector bar and cathode block bonding mix with visible metal beads.
HC8F	High conductivity, multi-purpose ramming mix

Industry-trusted Products	
C34	Two-component carbonaceous heat setting cement
C38	Two-component carbonaceous heat setting cement
C46	Single-component carbonaceous heat setting cement
CP9	Carbonaceous hot ramming paste
EZRAM RP10	Highly thermally conductive graphitic ram
SMART RAM® RP20	Thermally conductive, self-correcting ram with specially treated graphite flake
GR37	Two-component carbonaceous grout with expanding flake graphite
EZRAM RP3	Single component carbonaceous ram
EZRAM RP4	Single-component carbonaceous ram

TAPHOLE MATERIALS

Allied is the leader in high-alumina & anhydrous taphole clay sales in North America. We offer a comprehensive line of taphole clays that span from siliceous plugging pastes for the alloy industry to high-alumina clays designed for high production, multiple-taphole blast furnaces.

Taphole Materials for Blast Furnaces

RSR 101	For conventional drilling practice on medium-size furnaces producing 4000 - 6000 tons of hot metal per day
RSR 1170 R-AM	For blast furnaces producing 4000 - 6000 tons of hot metal per day with shorter gap times (25 - 30 minutes)
RSR 1170R Modified	Ideal for plants in urban environments
RSR 963-14	For high-production blast furnaces
Restoration Clay	Formulated to fill cracks and fissures in the taphole clay column of blast furnaces
RSR Green Tap	Low volatile products that promote easy drilling and extended hole length





PRODUCT INNOVATIONS

ALLIED PRODUCT FAMILIES

STACKCRETE®

The STACKCRETE® line features several products with **silicon carbide additions**, designed to match the unique properties and temperatures of each zone of blast furnace stacks. These products are suitable for **maintenance throughout the stack lining** and are designed to **withstand impact, abrasion, temperature fluctuation, slag attack, CO attack and alkali attack**. The STACKCRETE® line also features a **wide range of installation methods**.

STACKCRETE® G is Allied's innovative graphitic castable that can be used as both a repair and replacement material for carbonaceous refractory/brick. STACKCRETE® G offers:

Shortened installation time | Reduced labor cost | Reduced lead time compared with brick refractories | Can install using cast in place, gun or shotcrete technique



ALAKAST

ALAKAST is a line of castable refractories, ranging from no cement to conventional cement, that are ideal for various areas of steel reheat furnaces. Each ALAKAST mix is designed to meet a unique application requirement, such as volume stability, excellent flowability and high strength. These products also feature a variety of installation options.

BLAST KAST™

Our trademarked BLAST KAST™ products are designed for shotcrete installation, making them ideal for wall and roof applications in reheat furnaces. These low cement mixes are noted for their versatility and dependable delivery and performance.

V-CAST®

The V-CAST® line for iron-making is a collection of alumina-based castables with additions of silicon carbide and carbon. These products are recommended for use in a variety of applications, including blast furnace and cupola troughs, slag and iron runners, tilting runners, spouts, and tap holes. There is a V-CAST® product tailored to each application's unique operating temperature and conditions.



FLOORING: TUFFLOOR

TUFFLOOR is designed for areas exposed to extreme thermal cycling and intermittent exposure to liquid metal spills, dross and slag. It is a versatile product that can be installed as a complete floor, over existing (or new) concrete, or as precast tiles.

TUFFLOOR has years of success in repairs and rebuilds of casthouse floors, and has also proven successful in a wide variety of coke oven blast furnace and other integrated steel equipment areas.

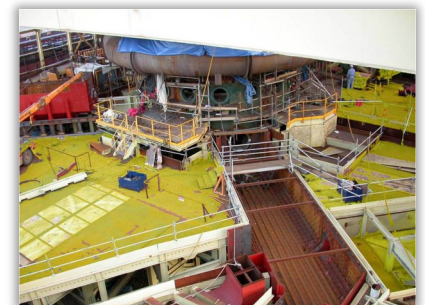



ADDITIONAL PRODUCTS

FILLING THE GAPS

SKAMOL

INSULATION BOARD

Allied carries SKAMOL's line of vermiculite based insulation boards that help save energy and reduce costs.

- SKAMOL VIP-12 HS BOARD
- SKAMOL VIP-12 HS CLICKBOARD

SKAMOL insulation board products help steel ladles preserve heat and maintain internal temperature. These products reduce lining thickness, increasing ladle capacity.

SKAMOL VIP-12 HS CLICKBOARD features an innovative perforated design that allows simple and fast installation.



INSULATING FIREBRICK

SKAMOL's collection of insulating firebrick, supplied by Allied, is the ideal choice for back-up insulation systems for hot blast stoves. These systems can be customized for high insulation properties or high strength.

- HIPOR 450
- POROS
- SUPRA

Benefits of SKAMOL insulating firebricks include low thermal expansion, reduced heat loss, high cold-crushing strength and resistance to alkali and acid attack.

OTHER SUPPORTING PRODUCTS

Allied carries the ancillary products you need to complete your process.

- Carbon firebrick
- Installation equipment
- Thermocouples and wire



TECHNICAL SUPPORT



FAST • FLEXIBLE • FOCUSED

Allied Mineral Technical Service, Inc. (AMTS) offers value added technical assistance in the critical areas of the blast furnace, hot blast stove and cupola. The AMTS team has decades of experience in the industry and is backed by Allied Mineral Products, a global leader in refractory technology and production.

AMTS Supports:

- Blast Furnaces
- Hot Blast Stoves
- Hot Blast Systems
- Casthouse Design
- Cupolas

Engineering and Design Services

Our value added technical assistance includes a range of data collection and analysis and engineering design capabilities to help optimize furnace operation.

- Hearth monitoring and modeling
- Failure diagnostics of hearth and taphole
- Innovative refractory selection
- New and spent refractory testing
- Advanced cooling systems
- STACKCRETE® high conductivity grout

Field Services

Our team is on site providing supervision and assistance to ensure your operations run safely and efficiently. Our support includes:

- Assistance for:
 - Core drilling
 - Grouting
 - Installation
 - Maintenance
- Emergency responsiveness
- Data collection equipment placement
- Refractory properties and behavior monitoring
- Analysis of melt practices
- Training on refractory best practices

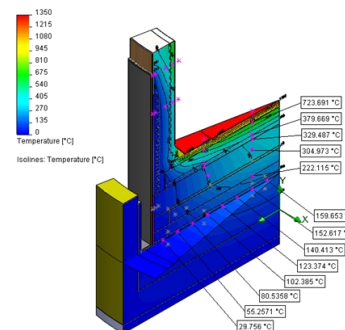
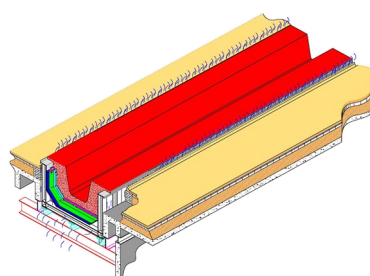
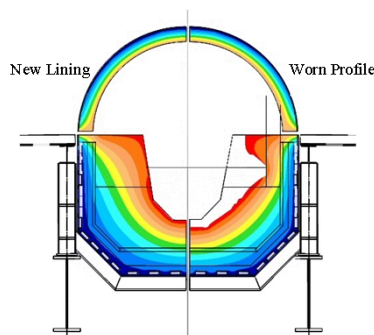
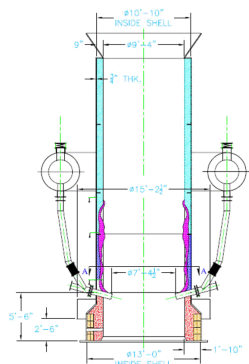

Allied Mineral Technical Services

AMTS@alliedmin.com | alliedmineraltechnicalservices.com



BLAST FURNACE



UPPER STACK

STACKCRETE® 62M

MIDDLE STACK

STACKCRETE® 21V

STACKCRETE® 608

STACKCRETE® 62M

LOWER STACK

STACKCRETE® G

STACKCRETE® AZS 5R

STACKCRETE® 62M

BOSH

STACKCRETE® G

STACKCRETE® 62M

TAPHOLE CLAY

RSR 101

RSR 1170R-AM

RSR 1170R-Modified

RSR 963-14

RSR GREEN TAP 5

RESTORATION CLAY

TAPHOLE STRUCTURE

V-CAST® 133A

V-CAST® 720A

V-CAST® 739A

Carbon Blocks

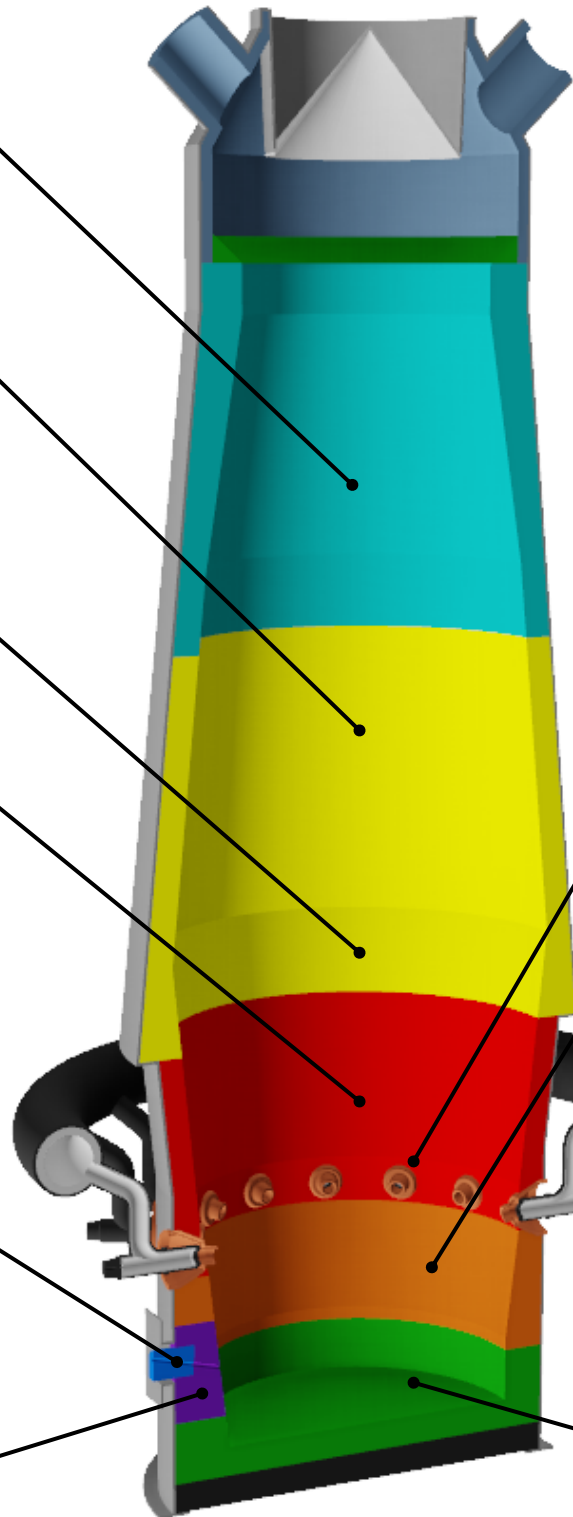

TUYERE SLEEVE

LCF 798A (Precast)

HEARTH

STACKCRETE® 20V

STACKCRETE® 18V

HC3F Mortar

C34 Cement

HC4F Grout

HC5F Grout

STACKCRETE® 62M

GUNCAST 12

BUSTLE PIPE

PUMPLITE 80 LI

LCF 798A Pump

BOTTOM & HEARTH CORNER

Ceramic Pad Shapes





CASTHOUSE

TROUGH / RUNNER

WORKING LINING

- V-CAST® 218A

- V-CAST® FA2L

- V-CAST® 418A

- V-CAST® 712A

- V-CAST® 719A

- V-CAST® 739A

- RAPID PUMP 2750 SC

SAFETY LINING

- DRI-VIBE® 660A

- RAM 491A

- CW 7929 Castable
(Precast retainer shape)

- MATRIPUMP 80

- TEK-PAK 664A

INSULATION

- Super Firetemp X

MAINTENANCE

- TEK-GUN 408A

- DRI-VIBE® 348A

- DRI-VIBE® 512A

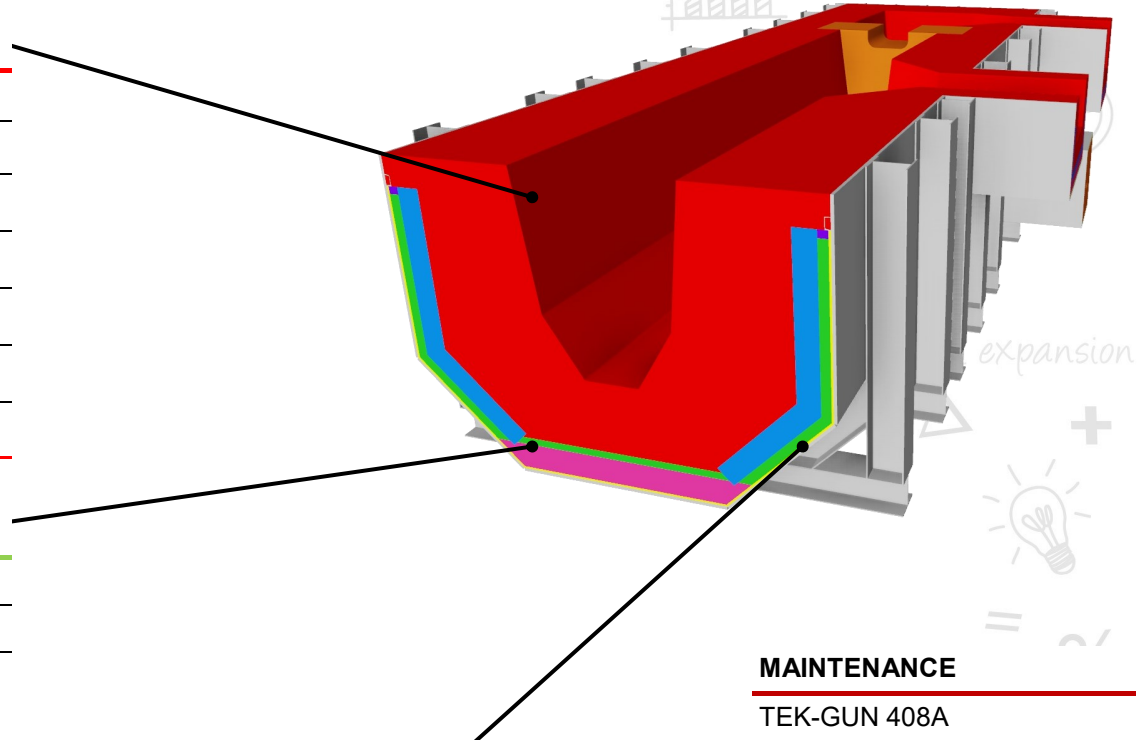

IRON TILTER

WORKING LINING

- V-CAST® 133A

- V-CAST® 712A

- V-CAST® 720A

SAFETY LINING

- MATRIPUMP 60

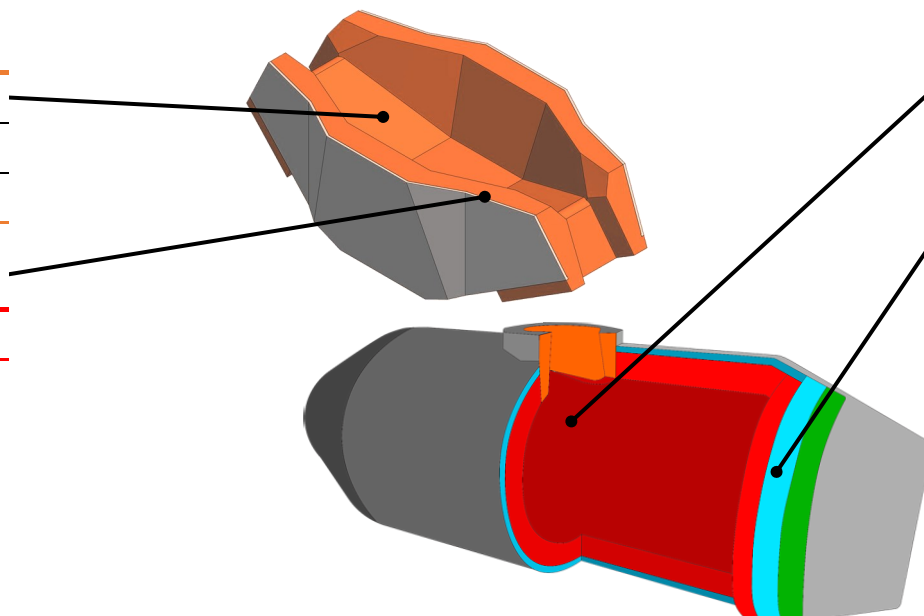

LADLE

WORKING LINING

- TUFFCRETE® 62M-FR

SAFETY LINING

- MATRIPUMP 60





REHEAT - PUSHER FURNACE

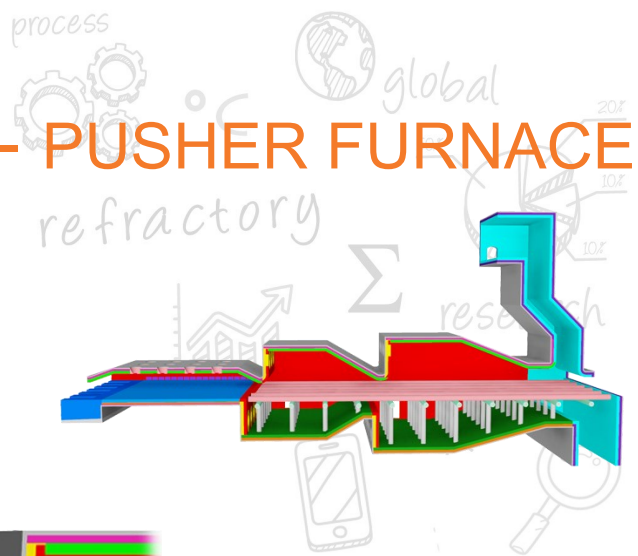

EXTRACTOR SHAPES

- ALAKAST 98 EZC
- ALAKAST 90 LC-P
- ULTRACON 34C

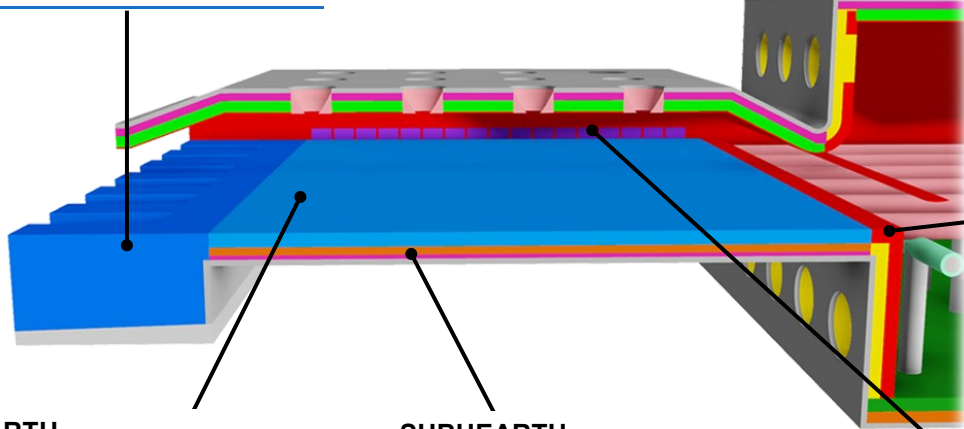

LEADING EDGE

- ALAKAST 98 EZC
- ALAKAST 90 LC-P
- TUFFCRETE® 90

HEARTH

- ALAKAST 98 EZC
- ALAKAST 90 LC-P
- TUFFCRETE® 90
- ALAKAST 85 LC-P-ES

SUBHEARTH

- ALAKAST 45-P
- ALAKAST 50 LC-P
- TUFF-FLO 50
- Super Firetemp X

BUMPER & SKID BLOCKS

- ALAKAST 98 EZC (Precast shape)
- ULTRACON 34C
- ALPHAMAX T

BURNER WALLS & ROOF

- BLAST KAST 70 LC

SIDE WALLS

- BLAST KAST 70 LC
- TUFF-FLO 50
- BLAST KAST 45 LC

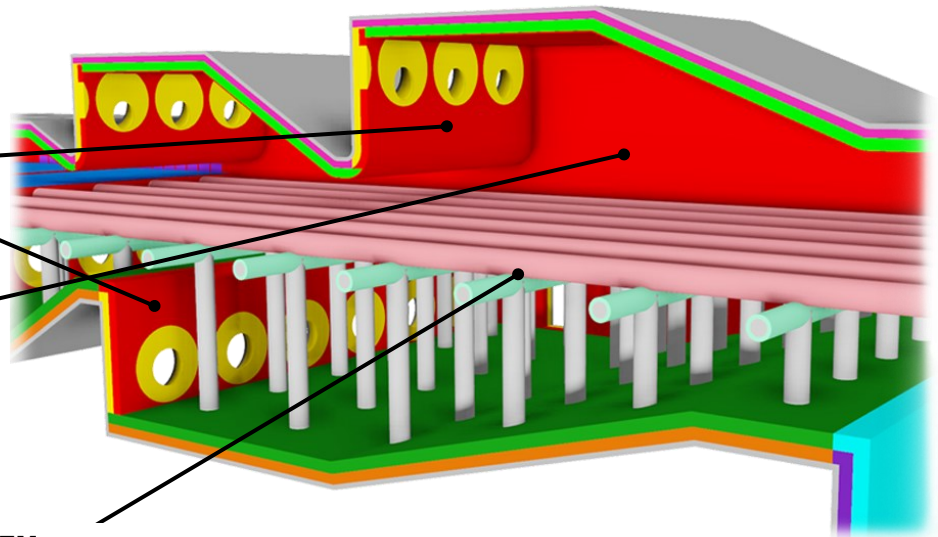

WET SKID SYSTEM

- ALAKAST 68 LC-P
- ALAFLOW 60 LC-P
- TUFF-FLO 65M





REHEAT - WALKING BEAM FURNACE



SIDE WALLS

BLAST KAST 70 LC

TUFF-FLO 50

BLAST KAST 45 LC

BURNER WALLS & ROOF

BLAST KAST 70 LC

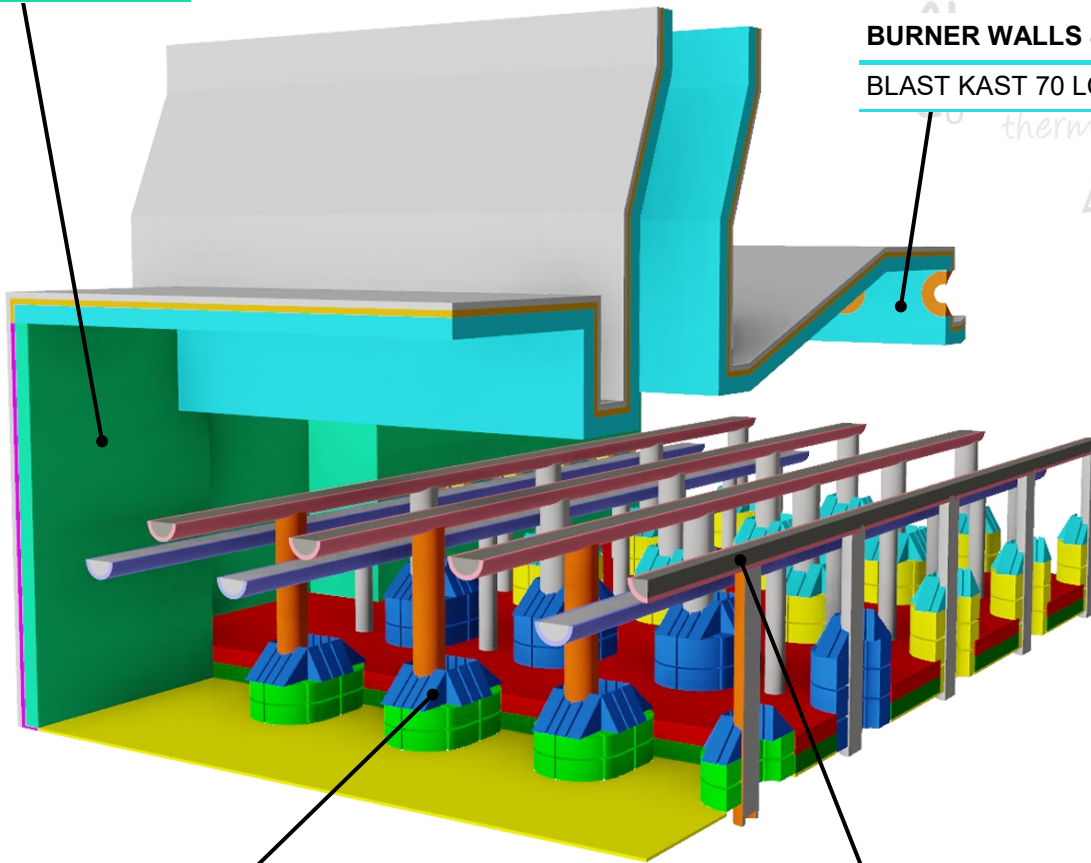

HEAT ZONE SLOT & DEFLECTOR BLOCKS

ALAKAST 45 LC
(Precast shape)

TUFF-FLO 50
(Precast shape)

ALAFLOW 60 LC-P
(Precast shape)

TUFF-FLO 65M
(Precast shape)

WET SKID SYSTEM

ALAKAST 68 LC-P

ALAFLOW 60 LC-P
(Precast shape)

TUFF-FLO 65M





REHEAT - ROTARY HEARTH



ROOF

BLAST KAST 70 LC

BURNER BLOCKS

LCF 798A

BRICKMIX 81

KAST TECH 60

MATRIPHOS 85AC

QUICK-FIRE® 88

SIDE WALLS

BLAST KAST 70 LC

TUFF-FLO 50

BLAST KAST 45 LC

CURBS

ALAKAST 68 LC-P

ALAKAST 50 LC-P

TUFF-FLO 65M

SKID BLOCKS

ALAKAST 98 EZC
(Precast shape)

ALPAHMAX T

ULTRACON 34C

INSULATION

Super Firetemp X

HEARTH

ALAKAST 90 LC-P

ALAKAST 68 LC-P

TUFF-FLO 60A

ALAKAST 50 LC-P

DURACON 32

SUBHEARTH

ALAKAST 45-P

ALAKAST 50 LC-P

TUFF-FLO 50

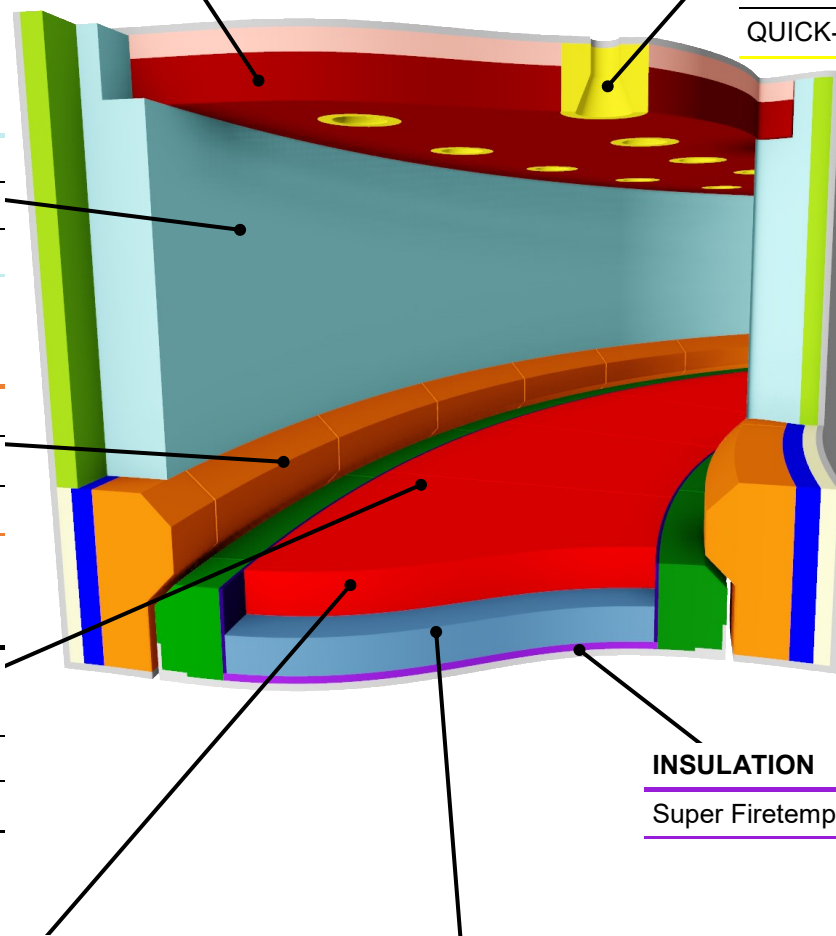

Headquarters:

Allied Mineral Products, LLC

Columbus, Ohio, U.S.A.

614-876-0244 - info@alliedmin.com

USA Manufacturing Locations:

Allied Mineral Products, LLC

Columbus, Ohio, USA

614-876-0244 - info@alliedmin.com

Allied Mineral Products

Chehalis, Washington, USA

614-876-0244 - info@alliedmin.com

Allied Mineral Products

Pell City, Alabama, USA

614-876-0244 - info@alliedmin.com

Allied Mineral Products

Brownsville, Texas, USA

956-831-2022 - info@alliedmin.com

International Manufacturing Locations:

Allied Mineral Products Brazil

Pocos de Caldas, Brazil

614-876-0244 - info@alliedmin.com

Allied Mineral Products Europe B.V.

Tholen, Netherlands

31-166 601200 - customer.service@alliedmin.com

Allied Mineral Products (Foshan) Co., Ltd.

Foshan City, China

86-22-252-10378 - chinasales@alliedmin.com

Allied Mineral Products (Tianjin) Co., Ltd.

Tianjin, China

86-22-252-10378 - chinasales@alliedmin.com

Allied Mineral Products South Africa (Pty) Ltd.

Johannesburg, South Africa

27-11-902-2900 - southafricasales@alliedmin.com

Allied Refractory Products India Private Ltd.

Ahmedabad, Gujarat, India

91-2717-616800 - india@alliedmin.com

Allied Mineral Products Russia

Elabuga, Tatarstan, Russia

79-16-585-2753 - info@alliedmin.com

Licensees:

Refractarios Lunge Limitada

Santiago, Chile

56-22-745-3613 - info@alliedmin.com

Nippon Crucible Co., Ltd.

Tokyo, Japan

614-876-0244 - japan@alliedmin.com

Shinagawa Refractories Australasia

Unanderra NSW Australia

+61-2-4222-3834 - info@alliedmin.com

Hagenburger

Grünstadt, Germany

31-16660-5153 - info@alliedmin.com

Visit alliedmineral.com for more information.